

IT-ES608-IM-4F

Industrial Ethernet Switch Hardware Installation Guide

【Introduction】

IT-ES608-IM-4F is a type of WEB managed redundant Industrial Ethernet Switch, which support 4 10/100M Ethernet ports(RJ45), 4 100M fiber ports, double power supply input and 1 route repay output. It supports SW-Ring patented technology (self-recovery time <20ms) to enhance the reliability of the network. What's more, IT-ES608-IM-4F supports several network managements, such as 802.1QVLAN, QoS, IGMP, port trunking and port mirroring. It has got the certification of CE, FCC and Industrial level 4 standard. It can meet the requirement of each type of industrial environment with the temperature range of -40 to 75°C.

【Packing List】

The IT-ES608-IM-4F switch is shipped with following items.

- IT-ES608-IM-4F Ethernet switch(Plus Terminal Block) ×1
- Hardware Installation Guide ×1
- CD-ROM with Windows Utility×1
- Product Warranty Statement ×1
- DIN-Rail setting fittings (wall mounting for optional)

【Features】

Specialized design for Industrial Application

- Industrial Level 4 design, accord with IEC61850 standard
- Dual power backup, reverse polarity protection
- support double relay input warning for power failure and one alarm output
- Port link, ring fault/abnormity alarm indication
- IP 30 protection, rugged high-strength metal case
- 24VDC power input (12~48VDC)
- -40~75°C operating temperature range
- DIN-Rail or panel mounting

Intellisystem Technologies S.r.l.

Via Augusto Murri, 1 - 96100 Siracusa - Phone +39 (0)931-1756256 / +39 (0)2-87167549 - Mobile (+39) 335 1880035
em@il: info@intellisystem.it WEB: <http://www.intellisystem.it>

Advanced Industrial Ethernet Networking Capability

- redundant self-recovery Ethernet ring (recovery time < 20 ms at full load)
- Store and forward.8k address. Support MAC address filtrate structure
- Support Web interface configuration
- Port-based VLAN, IEEE 802.1Q VLAN to ease network planning
- Support QOS
- Static IGMP multicast filter, is used for filtering multicast flow from Ethernet protocol.
- Port Trunking for optimum bandwidth utilization
- Port mirroring for online debugging
- Bandwidth management prevents unpredictable network status
- Lock port function for blocking unauthorized access based on MAC address

【Panel Layout】

IT-ES608-IM-4F

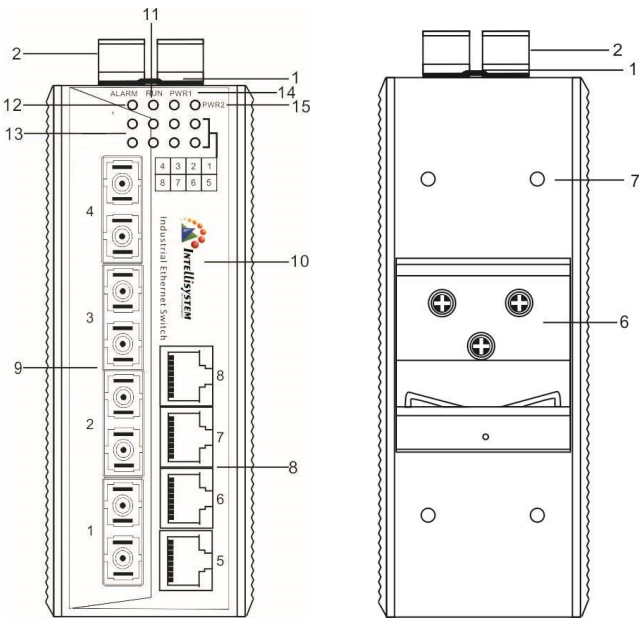

Front panel

Rear panel

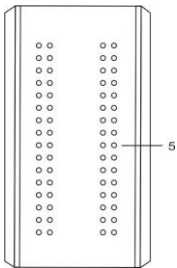

Top Panel

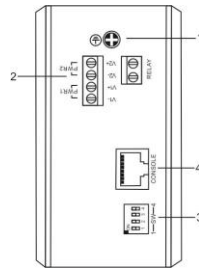

Bottom Panel

Intellisystem Technologies S.r.l.

Via Augusto Murri, 1 - 96100 Siracusa - Phone +39 (0)931-1756256 / +39 (0)2-87167549 - Mobile (+39) 335 1880035

em@il: info@intellisystem.it WEB: <http://www.intellisystem.it>

1. Grounding screw
2. PWR1/PWR2 input, relay output, 6 bit terminal block
3. DIP switch: DOWNLOAD PROGRAM, RESUME DEFAULT, SW-Ring Enabled
4. DOWNLOAD PROGRAM port (RS-232, RJ45)
5. Heat dissipation orifices
6. DIN-Rail locating kit
7. Screw hole for wall mounting kit
8. 10/100Base-T(X) Ethernet port
9. 100Base-FX Fiber port
10. Corporation, product information
11. Run indication LED
12. System alarm indication LED
13. Interface indication LED
14. Power input PWR1 LED
15. Power input PWR2 LED

Unit (mm)

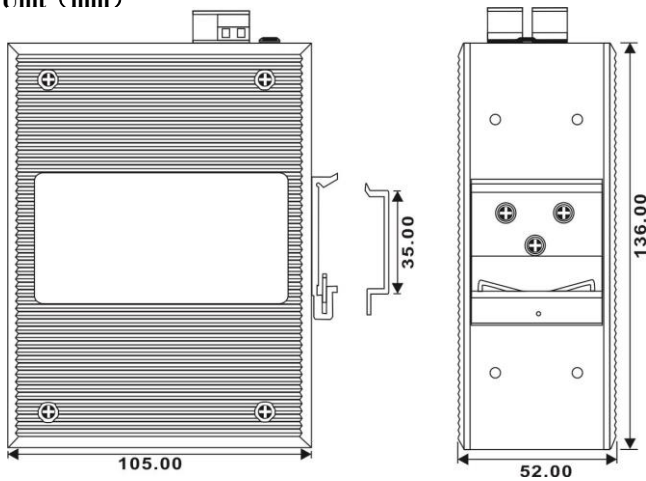

【Relay Contact】



The input terminal block is located in top panel of the device and it is also the contact of the device alarm. It is often off when no alarm happens, or it is turned on. IT-ES608-IM-4F supports 1 relay information output to connect alarm indicator or alarm buzzer to remind of operator in time in case of something happened.

Intellisystem Technologies S.r.l.

Via Augusto Murri, 1 - 96100 Siracusa - Phone +39 (0)931-1756256 / +39 (0)2-87167549 - Mobile (+39) 335 1880035

em@il: info@intellisystem.it WEB: <http://www.intellisystem.it>

【Power Input】

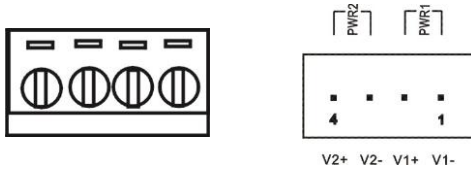

IT-ES608-IM-4F owns redundant power input, which provides two terminal blocks for PWR1 and PWR2 input. The redundant power can be used independently. PWR1 and PWR2 can supply power at the same time, once either of these two powers fails, another power can act as backup automatically to ensure reliability of the network. It also supports reverse polarity connection.

【Switch Setting】



Provide 4 bit switch for function setting (ON is enable): 1(ISP) is DOWNLOAD PROGRAM, 2 is RESUME DEFAULT, 3 and 4 is blank (NC).When the switch is setup, must be restart.

【Download Program Port】

IT-ES608-IM-4F provide one DOWNLOAD PROGRAM port (RJ45 type), on the top panel, manage the system with PC by RJ45-DB9F adapter.

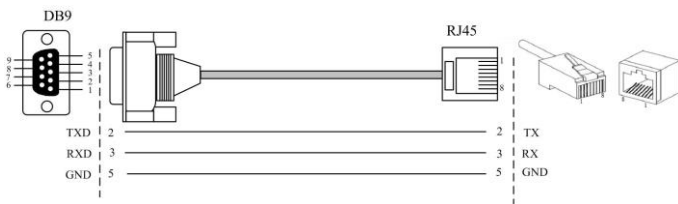

【Communication Connector】

IT-ES608-IM-4F contain 4 10/100BaseT(X) Ethernet ports (RJ45) and 4 100BaseFX (SC/ST connector, optional) fiber ports.

10/100Base-T(X) Ethernet port

The pinout of RJ45 port display as below, connect by UTP or STP. The connect distance is no more than 100m. 100Mbps is used 100 Ω of UTP 5, 10Mbps is used 100 Ω of UTP 3, 4, 5.

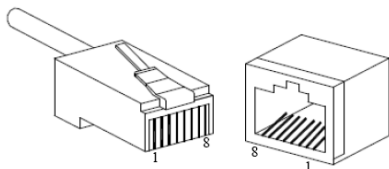

RJ 45 port support automatic MDI/MDI-X operation. Can connect the PC, Server, Converter and HUB .Pin 1,2,3,6 Corresponding connection in MDI. 1→3, 2→6, 3→1, 6→2 are used as cross wiring in the MDI-X port of Converter and HUB. 10Base-T/100Base-TX are used in MDI/MDI-X, the define of Pin in the table as below.

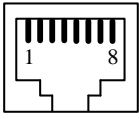

NO.	MDI signal	MDI-X signal
1	TX+	RX+
2	TX-	RX-
3	RX+	TX+
6	RX-	TX-
4、5、7、8	—	—

Note: "TX±"transmit data ±, "RX±"receive data ±, "—"not use

MDI (straight-through cable):

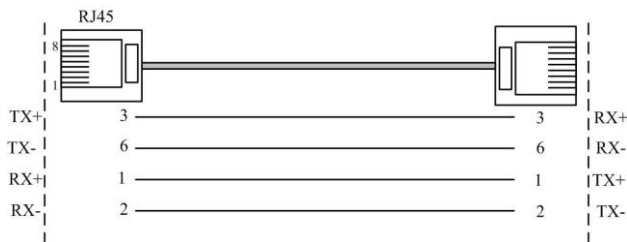

MDI-X (Cross-over cable):

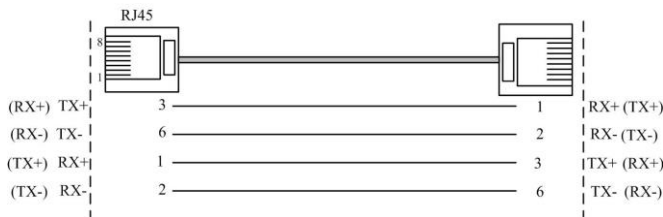

100Base-FX port

100Base-FX full-duplex SM or MM port, SC/ST type .The fiber port must be used in pair, TX (transmit) port connect remote switch's RX(receive) port; RX(receive) port connect remote switch's TX(transmit) port.

The optical fiber connection supports the line to instruct enhance the reliability of network effectively.

Suppose: If you make your own cable, we suggest labeling the two sides of the same line with the same letter (A-to-A and B-to-B, shown as below, or A1-to-A2 and B1-to-B2).

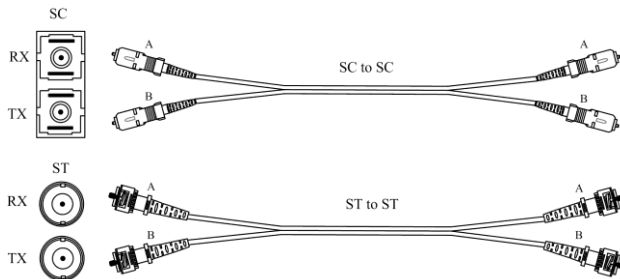

【LED Indicators】

LED indicator light on the front panel of IT-ES608-IM-4F. the function of each LED is described in the table as below.

System indication LED		
LED	State	Description
PWR1 (green)	ON	Power 1 is working normally.
	OFF	PWR1 is not connected or does not run normally.
PWR2 (green)	ON	Power 2 is working normally.
	OFF	PWR2 is not connected or run normally.
Alarm (green)	ON	Power or port link is broken or failure.
	OFF	power and port link is working well
Run (green)	ON/OFF	Device does not run normally
	Blinking	Device runs well
Link1~8 (green)	ON	Network connection of the port is valid
	Blinking	Data is being transmitted
	OFF	Network connection of the port is invalid

【Installation】

Before installation, please confirm that the work environment meet the installation requirement, including the power needs and abundant space, whether it is close to the connection equipment and other equipments are prepared or not.

- Examine the cables and plugs that installation requirements.
- Examine whether the cables be suitable or not (less than 100m) according to reasonable scheme.
- Screw, nut, tool provided by yourself.
- Power need: Redundant, dual 24VDC power inputs (12~48DC)

Environment: -40°C to 75°C

Relative humidity 5% to 95%

DIN-Rail Installation

In order to use in industrial environments expediently, IT-ES608-IM-4F adopts 35mm DIN-Rail installation, the installation steps as follows:

- Examine the DIN-Rail attachment
- Examine DIN Rail is firm or not and the position is suitable or not.

Intellisystem Technologies S.r.l.

Via Augusto Murri, 1 - 96100 Siracusa - Phone +39 (0)931-1756256 / +39 (0)2-87167549 - Mobile (+39) 335 1880035

em@il: info@intellisystem.it WEB: <http://www.intellisystem.it>

- Insert the top of the DIN-Rail into the slot just below the stiff metal spring.
- The DIN-Rail attachment unit will snap into place as shown below.

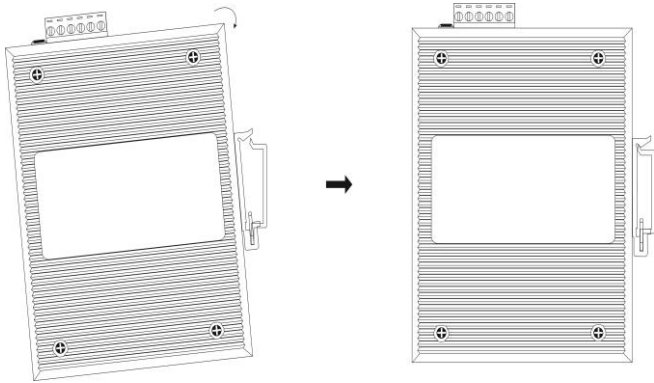

Wiring Requirements

Wiring need to meet the following requirements:

- It is needed to check whether the type, quantity and specification of cable match the requirement before cable laying;
- It is needed to check the cable is damaged or not, factory records and quality assurance booklet before cable laying;
- The required cable specification, quantity, direction and laying position need to match construction requirements, and cable length depends on actual position;
- All the cable cannot have break-down and terminal in the middle;
- Cables should be straight in the hallways and turning;
- Cable should be straight in the groove, and cannot beyond the groove in case of holding back the inlet and outlet holes. Cables should be banded and fixed when they are out of the groove;
- User cable should be separated from the power lines. Cables, power lines and grounding lines cannot be overlapped and mixed when they are in the same groove road. When cable is too long, it cannot hold down other cable, but structure in the middle of alignment rack;
- Pigtail cannot be tied and swerved as less as possible. Swerving radius cannot be too small (small swerving causes terrible loss of link). Its banding should be moderate, not too tight, and should be separated from other cables;
- It should have corresponding simple signal at both sides of the cable for maintaining

【Specifications】

Technology:

Standard: IEEE802.3、IEEE802.3u、IEEE802.3x、IEEE802.1Q、

IEEE802.1p、IEEE802.1D、IEEE802.1W

Protocol: SW-Ring、STP/RSTP、QoS、VLAN、PVLAN、

IGMP v1/v2/v3、SNMP v1/v2/v3、Telnet

Flow Control: IEEE802.3x control, backpressure control

Intellisystem Technologies S.r.l.

Via Augusto Murri, 1 - 96100 Siracusa - Phone +39 (0)931-1756256 / +39 (0)2-87167549 - Mobile (+39) 335 1880035

em@il: info@intellisystem.it WEB: <http://www.intellisystem.it>

Interfaces:

100M Fiber port: 100Base-FX, SC/ST optional

100M Ethernet Port: 10Base-T/100Base-TX, RJ45, auto-flow control, full/half duplex mode and MDI/MDI-X auto-connection

Console port: Based serial network management (RS-232), RJ45

Alarm output interface: One relay alarm output. Support power, port link and ring network alarm

Current Carrying Capability: 1A@30VDC

Processing type: Store and Forward

System exchange bandwidth: 2.0G

Cache: 1Mbits

MAC address: 2K

Priority queue: 4

VLAN No.: 256

VLAN ID: 1~4094

IGMP Groups: 256

Indicator:

Run indicator: Run

Interface indicator: Link1~8

Power indicator: PWR1、PWR2

Alarm indicator: Alarm

Transmission Distance:

Double-twisted cable: 100M (standard CAT5/CAT5e cable)

Multi-mode fiber : 850nm, 2Km

1310nm, 5Km

Single-mode fiber: 1310nm, 20Km

1310nm, 40Km

1310nm, 60Km

1550nm, 80Km

Power Supply:

Voltage input: 24VDC (12~48VDC)

Terminal Blocks: 4 cores 7.62mm terminal blocks

No-load power: 5.0W@24VDC

Full load power: 6.1W@24VDC

Support redundant protection

Support reverse polarity protection

Support overload current protection

Environment:

Operating Temperature: -40~75°C

Storage Temperature: -40~85°C

Relative Humidity: 5 to 95% (non-condensing)

Mechanical Structure:

Shell: IP30 protection, metal case

Installation: DIN-rail mounting

Weight: 800g

Dimensions (W×H×D): 136 mm×52mm×105mm

Approvals

EMI: FCC Part 15, CISPR (EN55022) class A

EMS: EN61000-4-2 (ESD), Level 4

EN61000-4-3 (RS), Level 3

EN61000-4-4 (EFT), Level 4

EN61000-4-5 (Surge), Level 4

EN61000-4-6 (CS), Level 3

EN61000-4-8, Level 5

Shock: IEC60068-2-27

Free Fall: IEC 60068-2-32

Vibration: IEC60068-2-6

Warranty: 5 years

【Certifications】

